

Workbench Assembly Instructions

An easy-to-build, strong, versatile workbench for under \$100



Photo 1 - The completed work bench

The instructions as shown will build a six foot long, by 31 inch deep by 31 inch high workbench with a shelf and pegboard back and pegboard sides.

Estimated Total build time:
3 - 4 hours (as shown)

Note that if a six foot table is too long, these instructions explain how to modify the design for any length.

SKILL LEVEL: EASY

Tools Required

- | | |
|--|--|
| <ul style="list-style-type: none"> ▪ Miter Saw ▪ Router with rounding bit ▪ Drill/Driver (with drill bits and Phillips screw bit) ▪ Mouse Sander (or comparable hand sander) | <ul style="list-style-type: none"> ▪ Circular Saw (with finishing blade - 186 teeth) ▪ Jig saw (with blade for smooth cutting) ▪ Hammer ▪ Measuring Tape |
|--|--|

Material Required

Quantity	Item
10	2"x4"s (8' long)
2	½" plywood (4'x8' sheet) (<i>OSB can be substituted for 1 sheet</i>)
1	Pegboard (4'x8' sheet)
1 box	6 x 1 ¼" Drywall (deck) screws
1 box	8 x 2 ½" Drywall (deck) screws
1 box	1 ½" 4d Finish nails

Optional Items

- Wood yardstick (to be mounted onto front of table if desired)
- Vise (to be mounted onto finished table if desired)
- Power strip (to be mounted on back board if desired)
- Stain (If desired, you can stain the workbench)
- Verathane (If desired, you can protect the workbench with a polyurethane product. Note that Verathane is a product by RustOleum that is like "liquid plastic" and protects better than standard polyurethane.)
- Peg Board hooks (so you can mount your tools)
- Wall-mountable Toilet paper holder (I'll explain why later)
- Wall-mountable Paper towel holder (don't forget to get a roll of shop towels).

Building the Structure

Start off by cutting the 2x4s. Use your Miter saw to cut eight 30 inch sections of 2x4. You should get 3 out of each piece of 2x4 with 6" left over on two and 36" left over on one. Cut four of the 2x4s 69 inches long. (See Figure 1) After cutting, you should still have three 2x4s left which we will use later to build the support for the peg board back and one longer piece (36") left from cutting the 30" long pieces. This piece will be used to build the shelf brace later.

Tip: A Miter saw with a laser sight makes this work fast!

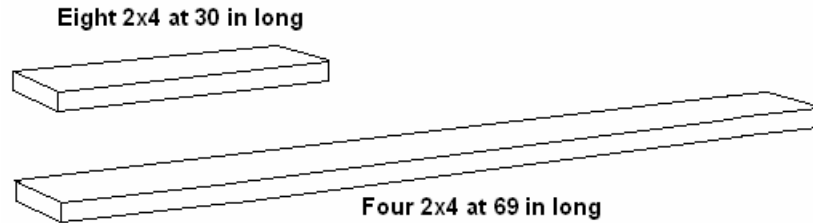

Figure 1: Cutting 2x4

After cutting the 2x4s as described, assemble the sides of the structure using two legs (30") and two sides (69") as shown in Figure 2. Place the first side at the top of the leg. Place the second side six inches from the end of the leg as shown in Figure 2. Make sure everything is square.

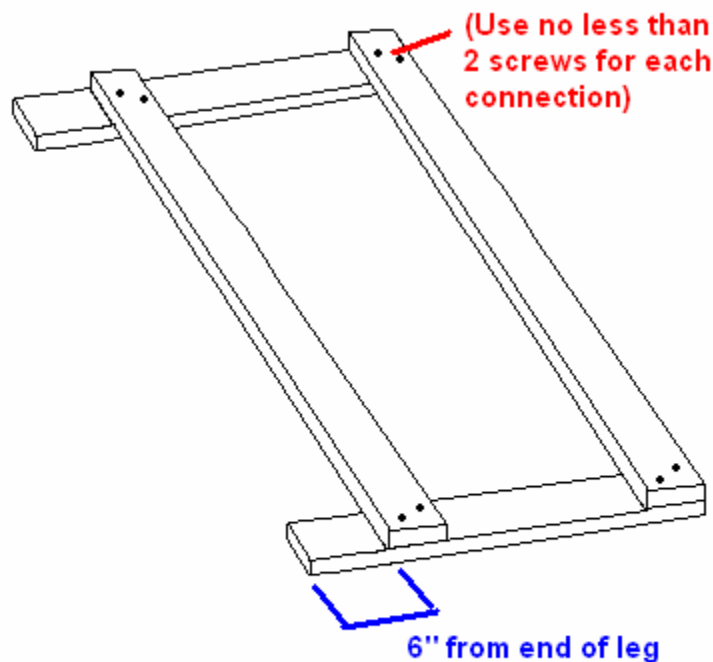

Figure 2: Side Assembly

Tip: Notice that the longer sides of the table are three inches shorter than your overall length. Since the overall length of the 6 foot table is 72 inches (6 ft = 72 in) then three inches shorter is 69 inches. You can use this bit of info in case you want to build a shorter table. If you want to make a shorter table then simply take off 3 inches on the side 2x4s from the overall length of the table. Example: A four foot table is 48 inches so the side 2x4s would then be 45 inches. Note that the legs and end pieces should still remain 30 inches.

After assembling the two sides lay the table upside down and connect the ends (30" pieces). See Figure 3 for a close up of how the joints are connected and Figure 4 to see what the structure should look like when done with this step. *(Graphic is color coded to make it easier).*

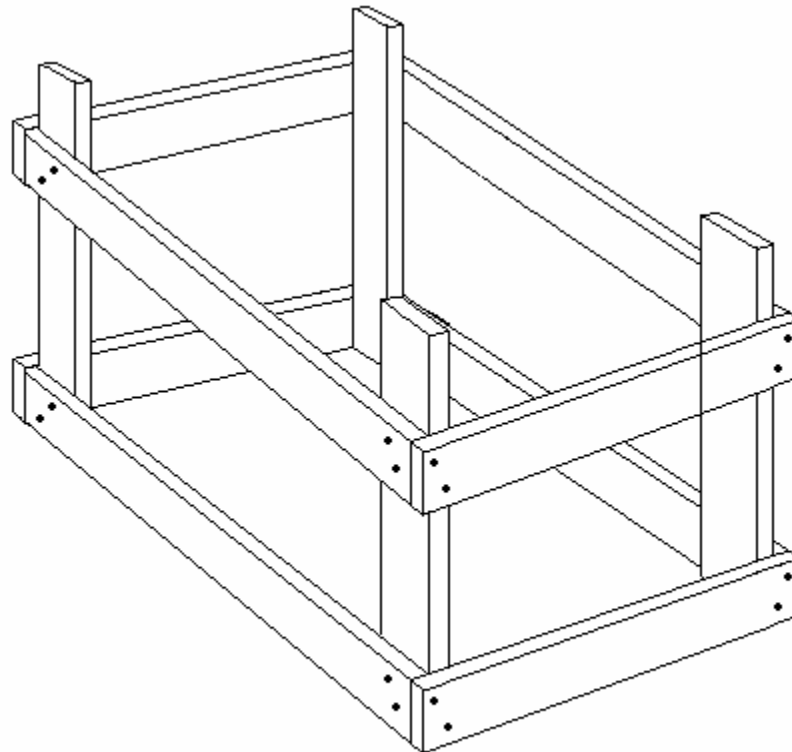
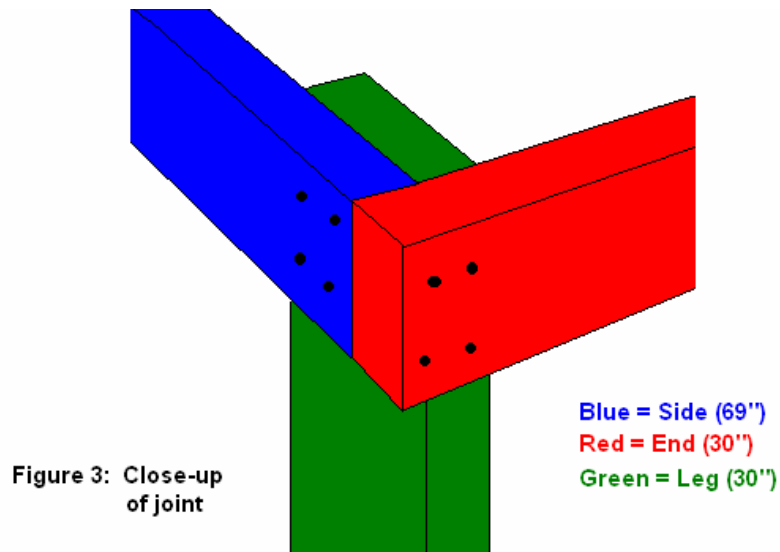

Figure 4: Finishing the Structure

Adding the Top

With the structure complete we are ready to add the top of the workbench. Turn over the structure and grab one of the pieces of plywood. Cut the plywood using your circular saw to fit your workbench size. For the six foot length, the plywood top should be cut to 6 foot x 31 inches. The additional 1 inch will be for an overhang of 1 inch in the front of the workbench. After cutting, then round off the front and the two sides with your router.

Tip: Using a straight-edge to mark the places to cut helps keep the cuts straight.

After routing the edges use the nails to nail the top onto your structure. Make sure to have the 1 inch overhang in the front.

Tip: For an added touch, if you have a set of screwdrivers like I do you need a place to keep them. Keeping them handy on the workbench is great for easy access. The easiest and cheapest way to do this is to drill out holes for each screwdriver in a straight line about 2 ½ inches apart along the back of the workbench for as many screwdrivers as you have. (See Photo 2) Do this before the pegboard back is mounted. One additional note, you can either use the same size of hole for each screwdriver or do what I did and use different sizes to match the screwdriver thereby making it easier to place them all back where they should be. Make sure you drill the holes far enough in from the edge so the drill doesn't try to drill through the wood structure below.



Photo 2 - Screwdriver storage

Adding the Shelf Brace

The Shelf Brace simply gives extra strength for the shelf and is fast to add. You should have one 2x4 that is 36 inches long that was left over from cutting the eight 30" long pieces. Use this wood and cut a 9 ¼" piece from it to use as the shelf brace. It should be touching the ground and flat on top so the shelf can rest over it as shown in Photo 3. Measure to the center of the workbench and screw it in at the center in the front. Screw the brace from the inside using the longer screws.



Photo 3 - Shelf Brace

Adding the Pegboard Back

Take the remaining three 2x4s and cut them using your miter saw to 5 ft long (60 inches). Attach them to the back of the work bench with the longer screws. Attach one on each end and one in the middle. (See Photo 4).

Cut the pegboard for the back with your jig saw (set on slow speed if you have the option) to 30" x 6' and attach with the smaller screws to the front.

Tip: If you plan on staining or painting your workbench it may be a good idea to actually add the pegboard after the staining or painting is done.

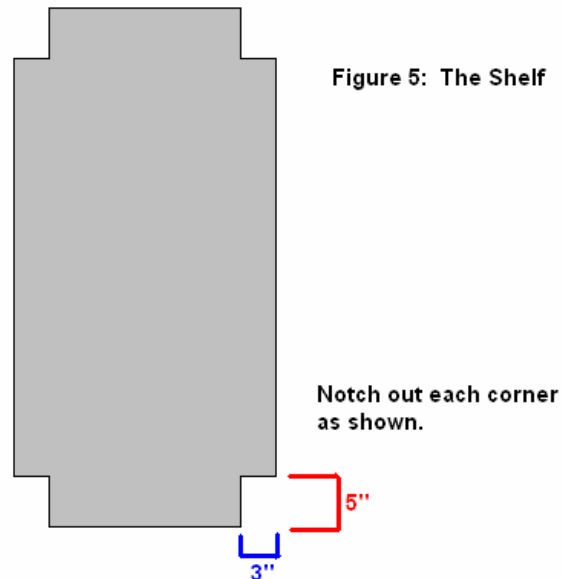

Photo 4 - Pegboard Back Bracing

Add the Shelf

With the second piece of plywood notch out the corners about 3" (on the ends) and 5" (on the front and back) with your jig saw. You may have to trim a little. Angle the shelf and slide it in from one of the ends to get it into place. Nail the shelf down with the nails. (See Figure 5).

Tip: If you want to save money and you have scrap 1/2" plywood or OSB around then try using smaller pieces and piece in the shelf, just make sure it is a tight fit. Add the notched out pieces first and work your way to the center. If you look closely at photo 1 you will notice this is what I did for my shelf.



Adding the Pegboard Sides (If desired)

Tip: The benefit of the sides is not only to hold more tools, but to also hide what you have on the shelf.

To add the sides, simply use some of the pegboard you have left and cut it using your jig saw to fit in the area on each side. A size that will fit fine on each side should be 16 ½" by 28"

This will be a simple rectangle shape. Screw it down with the smaller screws to the existing structure of the workbench. To see an example see photo 5.



Photo 5 - Pegboard Sides

Sanding and Finishing

Now sand the entire workbench with your sander. If you wish to stain or Verathane your workbench then now is the time.

Tip: If you want a light-colored stain color then don't use stain and only use Verathane. Verathane will make a nice rich light, rich looking color without staining.

Add Additional Features

- If you have a vise you can add it to the top of the workbench. (See Photo 1)
- If you obtained a wall mount toilet paper holder you can screw it to the side of the workbench. The toilet paper holder works well for holding rolls of tape. (See Photo 5)
- A roll of shop towels are always helpful. If you can't find one that mounts to the pegboard like I have (See Photo 5) then you can instead mount a paper towel holder to the wood. Of course the pegboard hooks won't work where the wood holds the pegboard back, but these are good places to mount a paper towel holder or a cordless screwdriver as shown in Photo 6.
- If you have a wood yard stick then nail it onto the front of the work bench (See Photo1 on front left side of workbench). The wood yard stick mounted on the front makes



Photo 6 - Attaching fixed items to the pegboard

- it very fast to measure small pieces of wood, nails, screws, etc.
- Attaching a power strip to your workbench makes it very easy to obtain power for your sanders and other tools.
- If you have a wall mountable paper towel holder then mount it to the side of the work bench for easy access to your shop towels.
- Attach your peg board hooks, hang your tools, and your new workbench is ready for use!

Tip: The shelf is large enough to not only store tools, but behind the tools additional items can be stored. I store used house paint behind the tools on my work bench.

Tip: Need a workbench for the middle of a room? Use the same instructions without the pegboard back and add a shelf brace on both the front and the back and router the top of the workbench on all four sides.

Tip: This workbench design can be used for more than just tools. This design makes a sturdy bench for any number of uses.

Tip: Have small children? Want to keep the kids from getting to items on the shelf? Simply add additional wood to the front and back of the workbench design using 1/4" plywood and hinges. This will help to keep small hands from getting in.

Workbench design instructions Copyright 2008 by John A. Scott.
These instructions are provided FREE and can be found at: www.scottfam.us

Please let us know if these instructions were helpful to you
by using the Feedback form on our site.